



US010864333B2

(12) **United States Patent**
Shimel et al.

(10) **Patent No.:** **US 10,864,333 B2**
(45) **Date of Patent:** **Dec. 15, 2020**

(54) **MEDICAL LIQUID WARMER WITH AUXILIARY TEMPERATURE SENSOR**

2205/3368 (2013.01); A61M 2205/502 (2013.01); A61M 2205/52 (2013.01); A61M 2209/084 (2013.01)

(71) Applicant: **ENTHERMICS MEDICAL SYSTEMS**, Menomonee Falls, WI (US)

(58) **Field of Classification Search**
CPC A61M 5/445; A61M 2209/084; A61M 2205/52; A61M 2205/3368; G05D 23/1931; A61J 1/10
See application file for complete search history.

(72) Inventors: **Kyle Shimel**, Waukesha, WI (US); **William J. Hansen**, Pewaukee, WI (US); **John Matthew Rotterman**, Waynesville, OH (US)

(56) **References Cited**

(73) Assignee: **Entermics Medical Systems**, Menomonee Falls, WI (US)

U.S. PATENT DOCUMENTS

(*) Notice: Subject to any disclaimer, the term of this patent is extended or adjusted under 35 U.S.C. 154(b) by 329 days.

| | | | | |
|--------------|------|---------|-------------|------------------------|
| 4,923,681 | A | 5/1990 | Cox et al. | |
| 6,384,380 | B1 * | 5/2002 | Faries, Jr. | A61G 12/001 219/385 |
| 6,536,943 | B1 * | 3/2003 | Feske | C09K 21/00 252/607 |
| 2001/0042743 | A1 * | 11/2001 | Faries, Jr. | A61F 7/0241 219/400 |
| 2003/0082069 | A1 | 5/2003 | Kuzyk | |
| 2003/0114795 | A1 * | 6/2003 | Faries, Jr. | A61M 5/44 604/113 |
| 2013/0197437 | A1 * | 8/2013 | Faries | A61M 5/44 604/113 |

(21) Appl. No.: **15/475,708**

(22) Filed: **Mar. 31, 2017**

(65) **Prior Publication Data**

US 2017/0281879 A1 Oct. 5, 2017

* cited by examiner

Related U.S. Application Data

Primary Examiner — Regis J Betsch
Assistant Examiner — Jeremy A Delozier

(60) Provisional application No. 62/316,972, filed on Apr. 1, 2016.

(74) *Attorney, Agent, or Firm* — Boyle Fredrickson S.C.

(51) **Int. Cl.**
A61M 5/44 (2006.01)
A61J 1/10 (2006.01)
G01K 15/00 (2006.01)
G05D 23/19 (2006.01)

(57) **ABSTRACT**

An auxiliary sensor can be used to measure the temperature of individual products in a heating cabinet. By arranging the temperature sensor with respect to the low mass thermal conductors and insulators, the sensor can be focused on the product to obtain the proper temperature irrespective of the immediate environment whether it is at room temperature or even within the heating cabinet.

(52) **U.S. Cl.**
CPC **A61M 5/445** (2013.01); **A61J 1/10** (2013.01); **G05D 23/1931** (2013.01); **A61M**

20 Claims, 4 Drawing Sheets

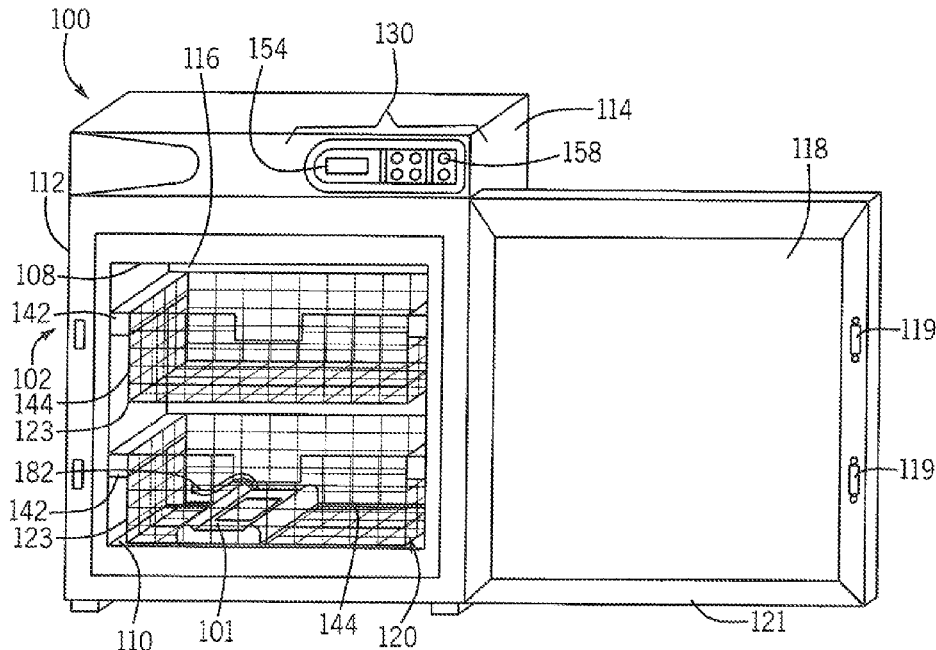

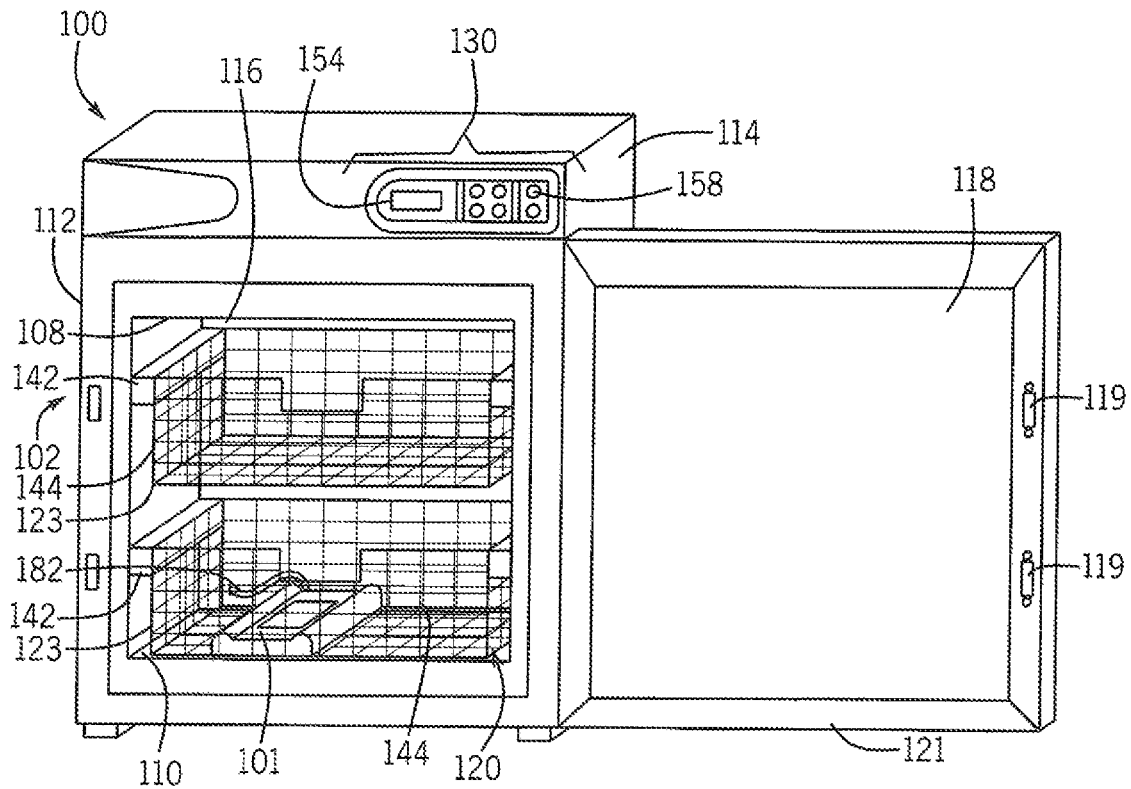

FIG. 1

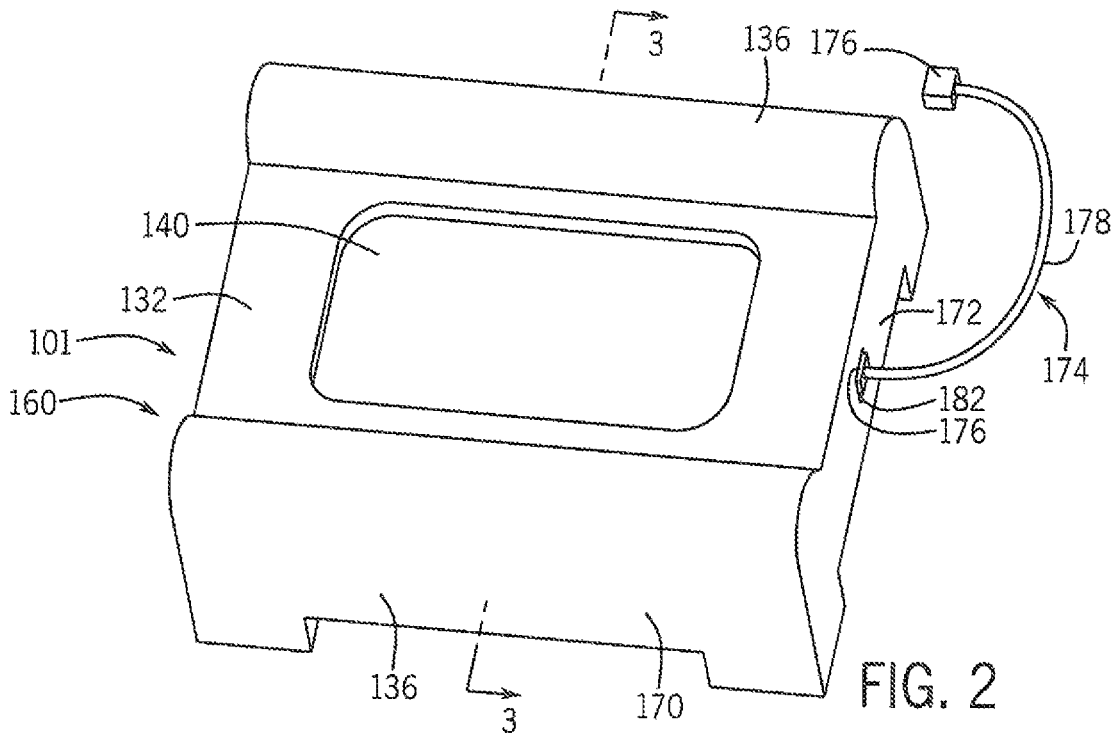

FIG. 2

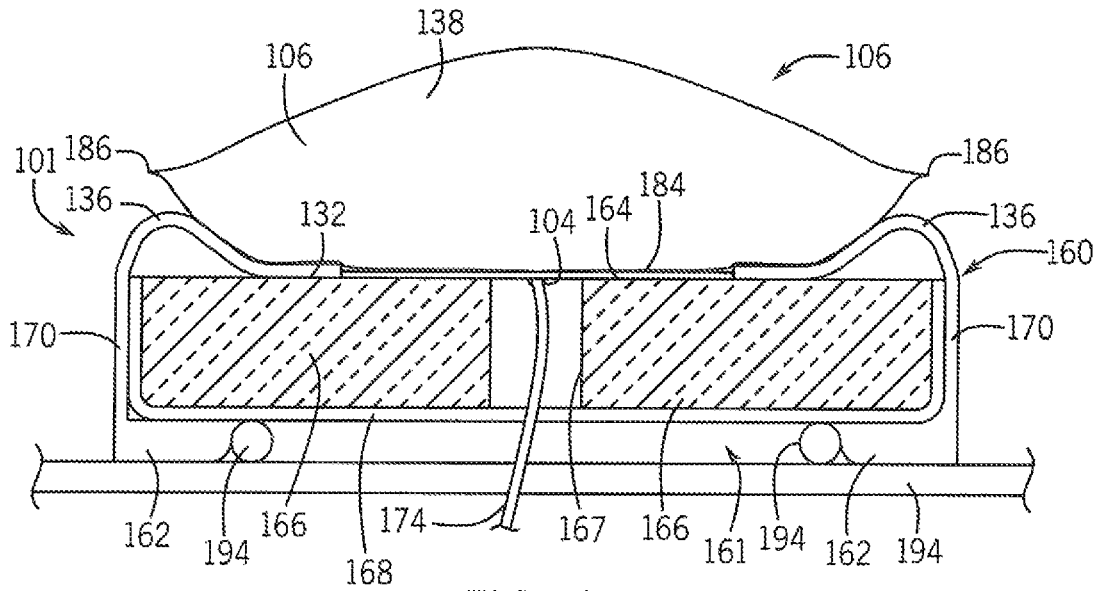

FIG. 3

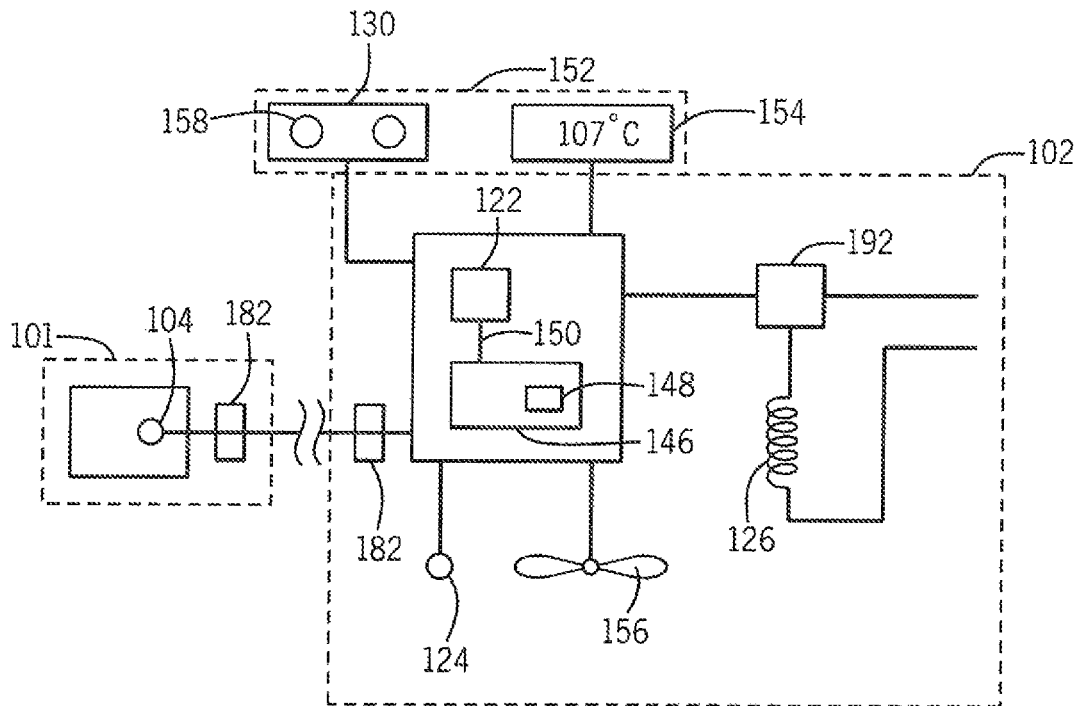

FIG. 4

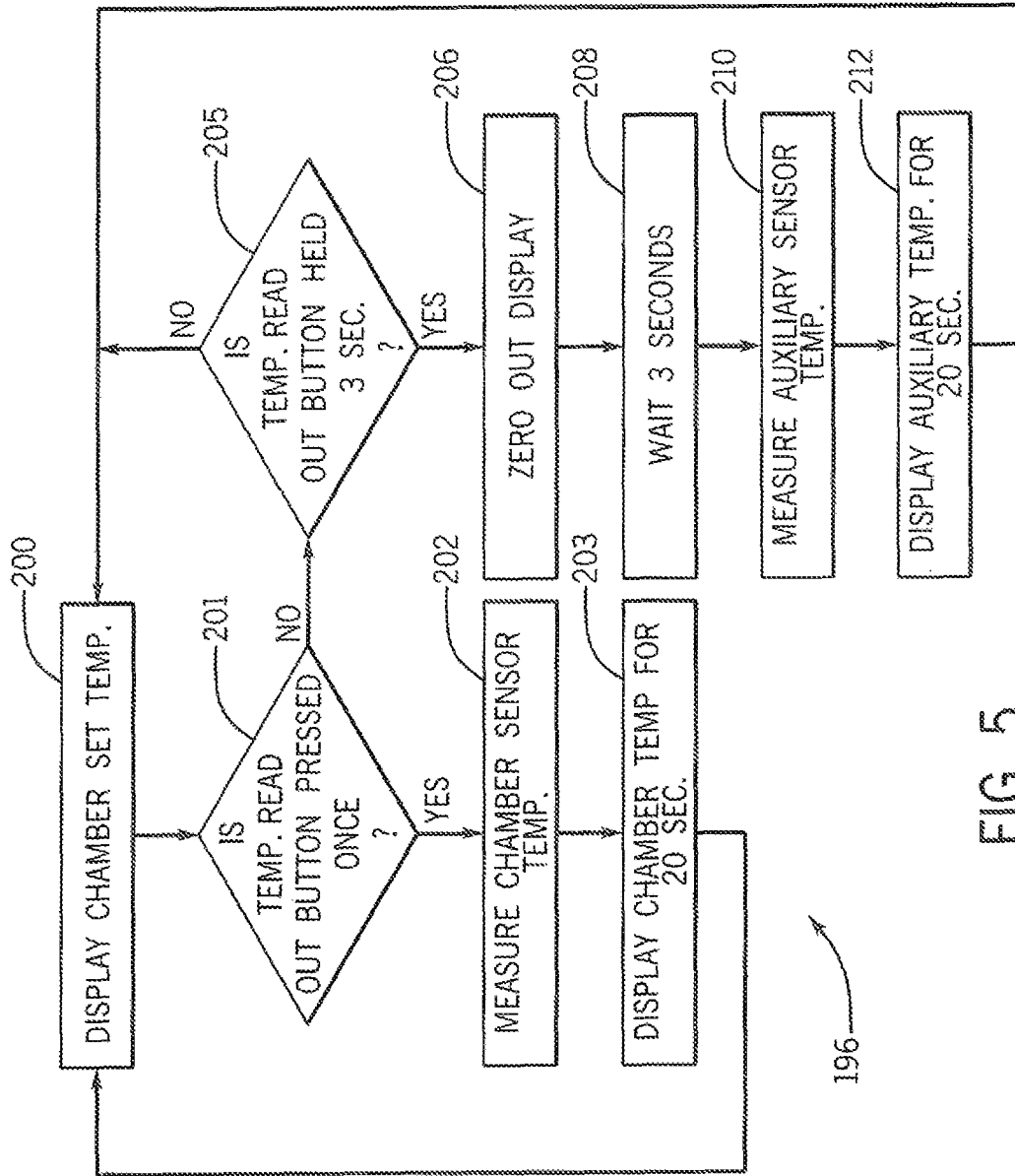

FIG. 5

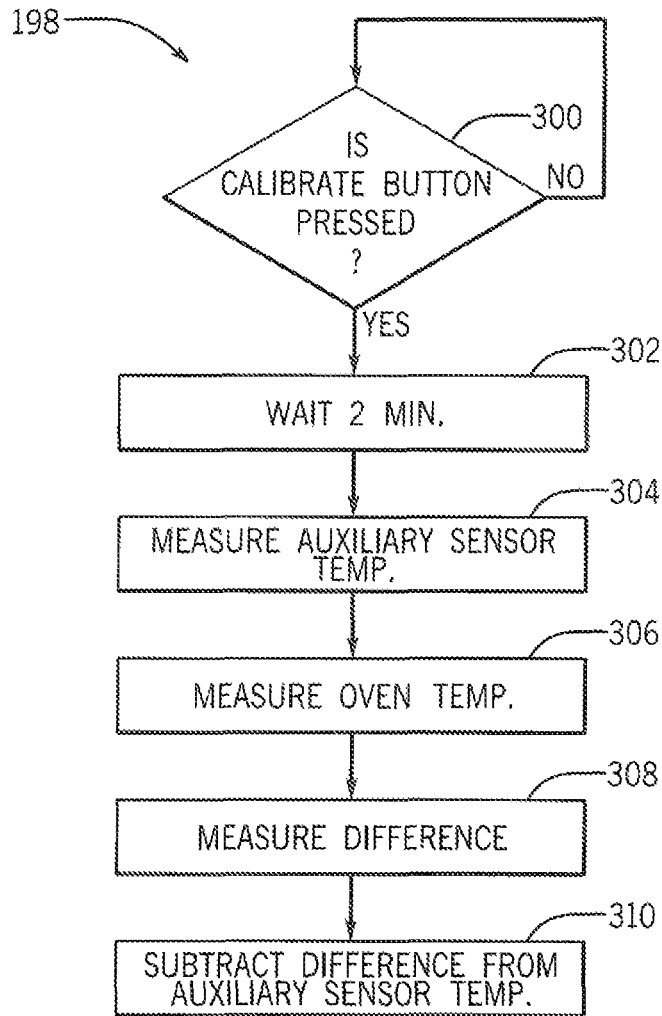

FIG. 6

**MEDICAL LIQUID WARMER WITH
AUXILIARY TEMPERATURE SENSOR****CROSS REFERENCE TO RELATED
APPLICATION**

This application claims priority to U.S. provisional application No. 62/316,972 filed Apr. 1, 2016 and hereby incorporated by reference.

BACKGROUND OF THE INVENTION

The present invention relates to warming systems for medical fluids, and in particular, to a warming cabinet with an auxiliary temperature sensor separate from the temperature sensor of the warming cabinet.

Warming cabinets for use in the medical industry are frequently used to maintain intravenous fluids at or near body temperature in order to maintain patient normothermia from admission to discharge. Maintaining the temperature and quality of intravenous fluids improves patient recovery, decreases blood loss, reduces surgical site infections, and reduces the length of hospital stays.

While warming cabinets typically ensure that product in the cabinets is quickly brought up to the proper body temperature, product recently introduced into the cabinets may not have achieved the proper temperature, allowing undesirably cool product to be introduced into the patient. In addition, if product is returned to the cabinet, how long it needs to remain in the cabinet may be unclear. This is particularly a problem because recently introduced product may be toward the front of the cabinet.

SUMMARY OF THE INVENTION

The present invention provides an auxiliary sensor that can be used to, measure the temperature of individual products in a heating cabinet. By arranging the temperature sensor with respect to the low mass thermal conductors and insulators, the sensor can be focused on the product to obtain the proper temperature irrespective of the immediate environment whether it is at room temperature or even within the oven.

In one embodiment, the present invention may be an auxiliary temperature monitoring system for measuring the temperature of an IV bag held within a warming cabinet, the system comprising a housing having an internal cavity; a heater adapted to heat the internal cavity; a sensor detecting a temperature of the internal cavity; and an auxiliary temperature device comprising an auxiliary housing, a heat collection plate supported by the housing and having an upwardly exposed upper surface configured to support the IV bag therein, and an auxiliary sensor configured to approximate a temperature of the heat collection plate.

It is thus a feature of at least one embodiment of the present invention to determine a temperature of an IV bag within a heating cabinet (or an IV bag just taken out of the heating cabinet) that is independent from the temperature reading of the interior cavity.

A feedback control system may receive the temperature of the internal cavity to control activation of the heater.

It is thus a feature of at least one embodiment of the present invention to utilize the heating cabinet heater for heating the IV bag but utilize the auxiliary temperature device for determining a temperature of the IV bag.

The plate may be sized to contact at least 30 percent of the surface of an IV bag supported by the auxiliary housing. The

heat collection plate may have an exposed area greater than 4 square inches or greater than 6 square inches.

It is thus a feature of at least one embodiment of the present invention to allow the heat collection plate to quickly adjust to and equalize with the IV bag temperature when within the internal cavity.

An entire lower surface of auxiliary housing beneath the heat collection plate may be insulated.

It is thus a feature of at least one embodiment of the present invention to isolate measurement of the heat collection plate to an upper surface contacting the IV bag.

The upper surface of the housing has opposed rails along opposite sides of the housing upper surface configured to retain an IV bag.

It is thus a feature of at least one embodiment of the present invention to support the length and width of the IV bags in a manner which facilitates temperature sensing toward a center of the IV bag.

An interior surface of the internal cavity has a releasable electrical connector adapted to receive a first end of a mating second electrical connector connected to the auxiliary temperature device.

It is thus a feature of at least one embodiment of the present invention to take temperature readings while the IV bag is within the interior cavity to reduce heat loss or disruption within the internal cavity.

The second electrical connector may communicate with the auxiliary temperature device through a flexible conductor.

It is, thus a feature of at least one embodiment of the present invention to be able to take temperature readings from outside of the interior cavity, e.g., when space within the interior cavity is limited.

An exterior surface of the housing may have a third electrical connector adapted to receive the second electrical connector wherein an opposite end is connected to the auxiliary temperature device.

It is thus a feature of at least one embodiment of the present invention to be able to take temperature readings of medical product whether or not they are placed within the warming cabinet.

A processor may operate a program stored in memory and communicate with the auxiliary sensor to determine an average temperature of the heat collection plate.

It is thus a feature of at least one embodiment of the present invention to detect an average temperature about an entire area of the IV bag.

The processor may operate a program stored in memory to communicate with a read out button to display the temperature of the auxiliary sensor on a warming cabinet display screen.

It is thus a feature of at least one embodiment of the present invention to display an auxiliary temperature through the heating cabinet's built in controller and display screen.

The processor may further operate the program stored in memory to communicate with a calibration button to compare the temperature of the warming cabinet sensor with the temperature of the auxiliary sensor and subtract a difference between the temperature of the sensor and the temperature of the auxiliary sensor from the temperature of the auxiliary sensor to calibrate the auxiliary sensor.

It is thus a feature of at least one embodiment of the present invention to calibrate the temperature sensor prior to use to adjust for heat loss or external factors affecting the auxiliary sensor.

3

The housing may be supported on feet extending downwardly from a bottom of the housing that are spaced apart to engage wire racks of the internal cavity therebetween the feet.

It is thus a feature of at least one embodiment of the present invention to balance the housing on a wire rack without tilting the IV bag.

The auxiliary temperature device may not have a heater.

It is thus a feature of at least one embodiment of the present invention to provide a standalone temperature measurement device.

The housing may be sized to contact less than 75 percent of a lower surface of the IV bag supported by the auxiliary housing.

It is thus a feature of at least one embodiment of the present invention to insulate the heat collection plate from the oven racks while supporting the IV bag.

The sensor may be bonded beneath the heat collection plate.

It is thus a feature of at least one embodiment of the present invention to provide an accurate representation of plate temperature without heat loss therebetween.

The heat collection plate may be a conductive metal. The heat collection plate may have a gauge thickness of less than or equal to 0.01 inches.

It is thus a feature of at least one embodiment of the present invention to provide fast conduction of heat from the plate to the sensor.

In one embodiment, the present invention may provide a method of detecting a temperature of an IV bag placed within a warming cabinet comprising a housing having an internal cavity; a heater adapted to heat the internal cavity; and a sensor detecting a temperature of the internal cavity, wherein the temperature is independent of the temperature of the warming, cabinet, and comprising the steps of: placing an auxiliary temperature device comprising an auxiliary housing, a heat collection plate supported by the housing and having an upwardly exposed upper surface configured to support an IV bag therein, and an auxiliary sensor configured to approximate a temperature of the heat collection plate within the warming cabinet; connecting the auxiliary temperature device to the warming cabinet; placing the IV bag on the heat collection plate; pressing the temperature read out button; and displaying the temperature of the heat collection plate on a display.

These particular objects and advantages may apply to only some embodiments falling within the claims and thus do not define the scope of the invention.

BRIEF DESCRIPTION OF THE FIGURES

FIG. 1 is a cabinet projection of a warming cabinet of the present invention and used with an auxiliary temperature sensor connected at the inside of the cabinet and supported within a basket;

FIG. 2 is a perspective view, viewed generally from above, of the auxiliary temperature sensor of FIG. 1 with the connector disconnected from the cabinet;

FIG. 3 is a cross section along line 3-3 of FIG. 2 showing an outer housing supporting a bag of intravenous fluid thereon, a heat collecting plate contacting the bag, a temperature sensor mounted to the underside of the heat collecting plate, and an insulating layer surrounding the temperature sensor, and where the outer housing is stabilized on lateral rods of the warming cabinet basket;

4

FIG. 4 is a block diagram of the functional components of the warming cabinet and the auxiliary temperature sensor in which the control provides a cabinet temperature or an auxiliary temperature;

FIG. 5 is a flow chart of the steps of operation of the warming cabinet of FIGS. 1-4 in implementing the present invention to selectively display the cabinet temperature of the cabinet sensor or auxiliary temperature of the auxiliary temperature sensor; and

FIG. 6 is a flow chart of the steps of operation of the warming cabinet of FIGS. 1-4 in implementing the present invention to calibrate the auxiliary temperature sensor.

DETAILED DESCRIPTION OF THE PREFERRED EMBODIMENT

Referring to FIG. 1, a warming system 100 may include a warming cabinet 102 to be used to warm a variety of items, such as intravenous fluids, blankets, and medicines and nutrimentals. The warming cabinet 102 may be generally rectangular and include a plurality of walls including a top wall 108 in parallel opposition to a bottom wall 110. Left, right, and rear edges of the top wall 108 and bottom wall 110 are joined by a left wall 112, a right wall 114 and a rear wall 116 which together define an interior warming chamber volume 120. A door 118 is hingedly attached to the right wall 114 to be moved to a closed position sealing the interior warming chamber 120. The door 118 also may be opened to access the interior warming chamber 120. Latches 119 may be provided keep the door 118 closed and/or the door may include a spring biasing it toward a closed position. The door may also include a seal 121 (which may be a compressible gasket or the like) between the door 118 and the walls when the door 118 is closed.

One or more shelves 123 may be arranged in the interior heating chamber 120 providing horizontally extending and vertically spaced support services subdividing the volume 120 to provide support for the items to be warmed therein or to increase the holding capacity of the cabinet 102. The shelves 123 may be in the form of wire baskets 144 held on support ledges 142 extending inwardly from the interior of the walls of the cabinet 102. The baskets 144 may be made of interwoven wires 194 or metal rods with longitudinal rods connected by transverse wires which are spaced at intervals from one another. The baskets 144 may be supported by the support ledges 142 at varying vertical distances so that two or more baskets 144 may be vertically spaced or stacked within the cabinet 102. The baskets 144 can slide in and out of the interior heating chamber 120 to facilitate insertion and removal of the items within the baskets 144. The baskets 144 may carry the items to be warmed, such as intravenous fluid bags 106.

As is understood in the art, the intravenous fluid bags 106, shown in FIG. 3, may be constructed of a flexible transparent plastic material, such as a vinyl, and fabricated by joining two sheets 184 of the material at a peripheral seam 186 to provide within the seam 186 an enclosed pocket into which sterile infusion liquid 138 may be held.

Referring to FIG. 4, the warming system 100 further includes a computer 190 with a processor 122 communicating with a memory 146, the latter holding a program 148 providing an operating system for the warming cabinet 102 and specific executable programs for temperature display and calibration as will be described below. The processor 122 may communicate via various I/O lines 150 which also allow the processor 122 to control or monitor different components of the warming cabinet 102 including a user

interface **152** with controls **130** and a visual display **154**, circulating fan **156**, controller **192** for heating elements **126**, temperature sensor(s) **124**, and auxiliary temperature sensor **104**.

The processor **122** may communicate with the temperature sensor(s) **124**, controller **192** for heating elements **126**, and circulating fan **156** to regulate a temperature of the interior warming chamber **120** as understood in the art. The temperature sensors **124** may be mounted to the walls of the warming cabinet **102** by a bracket or adhesive. The processor **122** may detect an interior temperature of the interior warming chamber **120** via the temperature sensors **124** and turn the heating elements **126** on or off according to a desired warming chamber **120** temperature.

In one embodiment, the number of temperature sensors **124** may correspond with the number of heating zones within the interior warming chamber **120**. For example, the processor **122** may be configured to independently monitor the temperature from temperature sensors **124** of each heating zone, and then further configured to independently control the heating elements **126** corresponding with each respective heating zone. This may be particularly useful when there is uneven warming within the interior warming chamber **120**, for example, because of uneven loading of items within the cabinet. The heating elements **126** may be arranged as heating pad subassemblies as described in U.S. Pat. No. 8,581,152, assigned to the present applicant, and hereby incorporated by reference.

The processor may communicate with a circulating fan **156** that may assist to circulate the air within the interior warming chamber **120** and to assist with intake and exhaust of air into and out of the interior warming chamber **120**. The circulation may help to reduce hot or cold spots within the chamber **120**.

The processor **122** may communicate with a user interface **152** including a visual display **128** and one or more controls **130**. The visual display **128** may be used in conjunction with the controls **130** to set the temperature of the interior warming chamber **120** and to show a set point temperature of the interior warming chamber **120** or of the individual heating elements **126**. The controls **130** may also include a read out button **158** to switch the display from the set point temperature of the interior warming chamber **120** to current temperature conditions (i.e., the temperature of one or more of the heated zones) of the cabinet **102** or a temperature of the auxiliary temperature sensor **104**.

Referring to FIGS. 1-3, the auxiliary temperature device **101** provides a generally rectangular housing **160**. The housing **160** may have vertically extending sidewalls (such as two longer sidewalk **170** connected by two shorter sidewalls **172**) and enclosed on a top end by a horizontal platform **132** for receipt of the intravenous fluid bag **106** thereon and a rectangular opening **140** to contact a heat collecting plate **164** within the opening **140** of the platform **132**.

The platform **132** may be a generally rectangular horizontal ceiling, of the housing **160** and may be surrounded by curved concave rails **136** extending upwardly from the platform **132** along the outer edges of the longer sidewalk of the platform **132**. For example, the curved rails **136** may be semi-cylinders. The curved rails **136** generally cradle an intravenous fluid bag **106** situated on the platform **132**.

The platform **132** also provides a rectangular opening **140** centered within the ceiling to expose the heat collecting plate **164** below the opening **140**. The opening **140** allows

the intravenous fluid bag **106** to contact the heat collecting plate **164** disposed within an interior of the housing **160** as further explained below.

In one embodiment, the platform **132** may be approximately 3 inches long by 4 inches wide or less than 15 square inches or less than 12 square inches. The platform **132** may be sized to contact less than 75 percent of the lower surface area of the intravenous fluid bag **106**. In this, respect, the edges of the intravenous fluid bag **106** may extend past the edges of the housing **160** while a center of the bag is substantially supported by the housing **160**.

In one embodiment, the opening **140** may be approximately 3 inches long by 2 inches wide or greater than 4 square inches or greater than 6 square inches. The opening **140** or exposed area of the heat collecting plate **164** may be sized to contact at least 30% of the lower surface area of the intravenous fluid bag **106**. In this respect, the contact area is large enough to facilitate, conduction from the intravenous fluid bag **106** to the heat collecting plate **164**.

Referring to FIG. 3, disposed within the housing **160**, and centered within the opening **140** of the platform **132** and generally pressed up against the upper opening **140**, is a heat collecting plate **164** contacting the intravenous fluid bag **106** when the intravenous fluid bag **106** is placed on the platform **132**. The heat collecting plate **164** may be a thin sheet of conductive metal, such as aluminum or copper, which contacts the intravenous fluid bag **106** and conducts the heat from the intravenous fluid bag **106**. The plate may have a minimal gauge thickness (e.g., about 0.01 inches or less than 0.1 inches) to provide low thermal mass (e.g., heat capacity of 003-0.09 J/gm K) to accelerate temperature measurement and has high conductivity.

An auxiliary temperature sensor **104** may be mounted to the underside of the heat collecting plate **164** and be positioned approximately in the center of the opening **140** to be near a center region of the contact with the intravenous fluid bag **106**. The auxiliary temperature sensor **104** may be mounted to the heat collecting plate **164** using an epoxy resin to provide good heat conductivity between the heat collecting plate **164** and the temperature sensor **104**.

The temperature sensor **104** detects an approximately average temperature, of the heat collecting plate **164**. It is contemplated that more than one temperature sensor may be used and their temperature readings averaged to approximate a heat collecting plate temperature. Temperature sensor **104** may be, for example, a thermocouple, a thermistor, a resistive temperature device, or other similar temperature sensing devices. As will be noted below, high linearity is not required because of the calibration system and the ability to process the received temperature signal with the processor **122**.

It is understood that the flexible material of the intravenous fluid bag **106** permits the intravenous fluid bag **106** to adopt a variety of different volumetric configurations, and the shape of the platform **132** is designed to promote contact of the intravenous fluid bag **106** with the temperature sensor **104**.

An undersurface of the heat collecting plate **164** and the auxiliary temperature sensor **104** is supported by and surrounded by an insulating material **166** reducing the temperature drop between the intravenous fluid bag **106** and the auxiliary temperature sensor **104**. The insulating material **166** may be a Styrofoam or other insulating foam material.

The insulating material **166** may be supported and sandwiched by a lower panel **168** thereby supporting the heat collecting plate **164**, auxiliary temperature sensor **104**, and insulating material **166** against the force of the intravenous

fluid bag **106** thereon. The lower panel **168** may be constructed of a metal sheet defining a floor of the housing **160** held in by the vertical sidewalls **170**, **172** of the molded plastic housing **160**. The lower panel **168** may be a substantially U-shaped frame or four sided box frame containing upwardly extending sidewalls surrounding a floor with the insulating material **166** carried within or between the sidewalls.

A channel **167** may extend through the insulating material **166** allowing an electrical connector **174** to extend from the temperature sensor **104** to an exterior of the housing **160**, for example, through a releasable electrical connector or jack **182**.

The vertical sidewalls **170**, **172** supporting the horizontal platform **132** of the housing **160** may be shaped so as to provide downwardly extending feet **162** at the lower corners of the housing **160** to lift and support the housing **160** on a table, shelf, basket, or the like. The feet **162** may curved around the lower corners of the housing **160** with carve-outs **161** extending along the lengths of the housings between the feet **162**.

In one embodiment, when the auxiliary temperature device **101** is supported in the basket **144**, as shown in FIGS. **1** and **3**, the carve-outs **161** provided between adjacent feet **162** allows the auxiliary temperature device **101** to rest on the spaced wire **194** or metal rods of the baskets **144** without unwanted movement. In particular, the interval between longitudinal rods of the basket or length of the carve-outs **161** may correspond with the space between adjacent feet **162** of the housing **160**.

Generally the housing **160** and platform **132** will be fabricated from injection molded thermoplastic or the like.

Referring to FIGS. **1** and **2**, in operation, the auxiliary temperature device **101** may be connected to the warming cabinet **102** through a releasable electrical connector or jack **182** on the interior or exterior wall of the warming cabinet **102** to communicate with the processor **122** of the warming cabinet **102**. The connection may be made via an electrical connector **174** having first and second modular connectors **176**, similar to telephone plugs, at opposite ends of the connector cord **178**. The modular connectors **176** are insertable into, a mating socket or jack **182**. The first modular connector **176** is insertable into a jack **182** of the cabinet **102** and the second modular connector **176** is insertable into a jack **182** of the auxiliary temperature device **101**, connecting the auxiliary temperature device **101** to the warming cabinet **102**. The connector cord **178** may be coiled, similar to a coiled telephone cord, allowing it to be flexible and extensible from the warming cabinet **102**.

The jack **182** of the cabinet **102** may be located on an interior wall of the interior warming chamber **120**, such as a lower end of the rear wall **116**, or on an exterior wall of the warming cabinet **102**, or in both positions to allow the auxiliary temperature device **101** to be used in both configurations. The jack **182** of the auxiliary temperature device **101** may be on a sidewall **172**. When the auxiliary temperature device **101** is connected inside the interior heating chamber **120**, the device may be positioned within the chamber **120** such as on shelf **123**, within the basket **144**, or on the floor **110** of the chamber **120**. When the auxiliary temperature device **101** is connected to an exterior wall, the device **101** may be positioned on top of the warming cabinet **102**, a table besides the warming cabinet **102**, or elsewhere near to the warming cabinet **102** during use.

It is contemplated that the temperature sensor **104**/auxiliary temperature device **101** and processor **122** may also

communicate through a wireless communication standard, such as Bluetooth, Wi-Fi, and the like, as understood in the art.

When the user desires a temperature of the intravenous fluid, bag **106** to be measured, the intravenous fluid bag **106** is placed on the platform **132**, as seen in FIG. **3**. In particular, the platform **132** is shaped to support the intravenous fluid bag **106** with one lower sheet **184** of the intravenous fluid bag **106** lying in close abutment to the platform **132**. In this way, contact between the intravenous fluid bag **106** and the heat collecting plate **164** may be, substantially maximized and the thermal path between the fluid and the sensor substantially maximized. The edges of the intravenous fluid bag **106** may be cradled by the rails **136** so that a width of the bag lies substantially within the platform **132** while a length of the bag may extend outwardly past an edge of the platform **132**.

Referring to FIG. **5**, the processor **122** operates to display a temperature of the interior heating chamber **120** or an, auxiliary temperature device **101**, as provided in the sequence of process steps shown as **196**, when activated by the user.

As indicated by process block **200**, the processor **122** normally displays a chamber set point temperature (i.e., the temperature at which the user sets or programs the cabinet).

As shown in process block **201**, the processor **122** may determine whether a read out button **158** is pressed. If the read out button **158** has been pressed once, the processor **122** will receive a temperature signal measured from the chamber temperature sensor **124** indicating a temperature of the interior heating chamber **120** as shown in process block **202**.

The processor **122** will then display a current state temperature (i.e., the temperature of one or more of the heated zones) of the cabinet **102** via the temperature sensors **124** of the interior heating chamber **120** and display it on the visual display **128** for a predetermined time period, as shown in process block **203**. For example, the predetermined time may be 20 seconds or 10-20 seconds. Alternatively, the current state temperature may continue to be shown until the user presses a control button **130**, such as read out button **158** once again, to switch the temperature signal input from the temperature sensors **124** back to the chamber set point temperature.

If the read out button has not been pressed once, the processor **122** may proceed to process block **205**. As shown in process, block **205**, the processor **122** may determine whether read out button **158** has been pressed for a predetermined time period, e.g., for more than three seconds. If so, the processor **122** will proceed to step **206**.

As indicated by process block **206**, when the user indicates that he or she would like to determine an auxiliary device temperature by pressing the read out button **158** for a predetermined time period, e.g., three or more seconds, the visual display **128** will be zeroed out and will no longer display the chamber set temperature.

As indicated by process block **208**, the processor **122** will wait a predetermined time period, such as three or three to five seconds, to allow time for heat transfer from the intravenous fluid bag **106** to the heat collecting plate **164** and to accommodate the response time of the auxiliary temperature sensor **104**. As is understood in the art, the program may extrapolate an asymptotic temperature value from a short measurement time.

As indicated by process block **210**, after the predetermined time has passed, the processor **122** receives a tem-

perature signal measured from the auxiliary temperature sensor **104** indicating a temperature of the intravenous fluid bag **106**.

As indicated by process block **212**, the temperature of the intravenous fluid bag is displayed on the visual display **128**. The auxiliary temperature sensor **1** temperature may be displayed for a predetermined time period, for example, 20 seconds or 10-20 seconds, before returning to process block **200**. Alternatively, auxiliary temperature may continue to be displayed until the user presses a control button **130**, such as read out button **158**, to switch the temperature signal input from the auxiliary temperature sensor **104** back to chamber set point temperature.

Referring to FIG. **6**, optionally as shown in **198**, the auxiliary temperature sensor **104** may be calibrated before use by placing the auxiliary temperature device **101** within an empty warming cabinet **102**. When the auxiliary temperature device **101** is connected to the warming cabinet **102**, the processor **122** will determine whether the user has initiated calibration by pressing the calibrate button of the user interface **152**, as seen in process block **300**. If calibration is initiated by the user, then the process will continue to process block **302**. If calibration is not initiated, then process block **300** is repeated until the calibrate button is pressed.

As indicated by process block **302**, once calibration is initiated, the process waits a designated amount of time, such as two or one to five minutes, to allow the auxiliary temperature device **101** to reach the interior heating chamber **120** temperature. Again an asymptotic temperature value may be extrapolated.

As indicated by process block **304**, after the auxiliary temperature device **101** has reached the same temperature as the chamber **120**, then a temperature measurement is taken at the auxiliary temperature sensor **104**.

As indicated by process block **306**, the processor proceeds to take a temperature measurement of the interior heating chamber **120** at the temperature sensors **124** at the walls of the interior heating chamber **120**. As indicated by process block **308**, the temperature measurement at the auxiliary temperature sensor **104** and at the temperature sensors **124** are compared and a difference is measured.

As indicated by process block **310**, this difference is subtracted from the reading at the auxiliary temperature sensor **104** to “zero the offset” of the auxiliary temperature sensor **104** and calibrate the temperature for any future temperature readings.

Certain terminology is used herein for purposes of reference only, and thus is not intended to be limiting. For example, terms such as “upper”, “lower”, “above”, and “below” refer to directions in the drawings to which reference is made. Terms such as “front”, “back”, “rear”, “bottom” and “side”, describe the orientation of portions of the component within a consistent but arbitrary frame of reference which is made clear by reference to the text and the associated drawings describing the component under discussion. Such terminology may include the words specifically mentioned above, derivatives thereof, and words of similar import. Similarly, the terms “first”, “second” and other such numerical terms referring to structures do not imply a sequence or order unless clearly indicated by the context.

When introducing elements or features of the present disclosure and the exemplary embodiments, the articles “a”, “an”, “the” and “said” are intended to mean that there are one or more of such elements or features. The terms “comprising”, “including” and “having” are intended to be inclusive and mean that there may be additional elements or

features other than those specifically noted. It is further to be understood that the method steps, processes, and operations described herein are not to be construed as necessarily requiring their performance in the particular order discussed or illustrated, unless specifically identified as an order of performance. It is also to be understood that additional or alternative steps may be employed.

References to “a controller” and “a processor” should be understood to include one or more microprocessors that can communicate in, a stand-alone and/or a distributed environment(s), and can thus be configured to communicate via wired or wireless communications with other processors, where such one or more processor can be configured to operate on one or more processor-controlled devices that can be similar or different devices. Furthermore, references to memory, unless otherwise specified, can include one or more processor-readable and accessible memory elements and/or components that can be internal to the processor-controlled device, external to the processor-controlled device, and can be accessed via a wired or wireless network.

It is specifically intended that the present invention not be limited to the embodiments and illustrations contained herein and the claims should be understood to include modified forms of those embodiments including portions of the embodiments and combinations of elements of different embodiments as come within the scope of the following claims. All of the publications described herein, including patents and non-patent publications, are hereby incorporated herein by reference in their entireties.

What we claim is:

1. An auxiliary temperature monitoring system for measuring the temperature of an IV bag held within a warming cabinet, the system comprising:

- a housing having an internal cavity;
- at least one electric heater fixed to the housing and adapted to heat the internal cavity;
- a sensor detecting a temperature of air of internal cavity and communicating with the at least one electric heater to control a temperature of the internal cavity; and
- an auxiliary temperature device repositionable within the internal cavity independent of a position of all electric heaters, the auxiliary temperature device-comprising:
 - an auxiliary housing,
 - a heat collection plate supported by the housing and having an upwardly exposed upper surface configured to support an IV bag thereon opposite a lower surface supporting an insulating layer, the insulating layer positioned between the heat collection plate and the air of the cavity and configured to block heat transfer from the air of the cavity to the lower surface of the heat collection plate, and
 - an auxiliary sensor supported by the heat collection plate and configured to provide a temperature of the IV bag substantially independent of the temperature of the air of the internal cavity.

2. The system of claim **1** further comprising a feedback control system receiving the temperature of the internal cavity from the sensor to control activation of the heater.

3. The system of claim **1** wherein the plate is sized to contact at least 30 percent of a lower surface of an IV bag supported by the auxiliary housing.

4. The system of claim **3** wherein the heat collection plate has an exposed area greater than 4 square inches.

5. The system of claim **4** wherein the exposed area of the heat collection plate is greater than 6 square inches.

11

6. The system of claim 1 wherein an entire lower surface of the auxiliary housing beneath the heat collection plate is insulated.

7. The system of claim 1 wherein the upper surface of the housing has opposed rails along opposite sides of the housing upper surface configured to retain the IV bag.

8. The system of claim 1 wherein an interior surface of the internal cavity has a releasable electrical connector adapted to receive a first end of a mating second electrical connector connected to the auxiliary temperature device.

9. The system of claim 8 wherein the second electrical connector communicates with the auxiliary temperature device through a flexible conductor.

10. The system of claim 8 wherein an exterior surface of the housing has a third electrical connector adapted to receive the second electrical connector wherein an opposite end is connected to the auxiliary temperature device.

11. The system of claim 1 further comprising a processor operating a program stored in memory to communicate with the auxiliary sensor to determine an average temperature of the heat collection plate.

12. The system of claim 11 wherein the processor operates the program stored in memory to communicate with a read out button to display the temperature of the auxiliary sensor on a cabinet display screen.

13. The system of claim 12 wherein the processor further operates the program stored in memory to communicate with a calibration button to compare the temperature of the sensor with the temperature of the auxiliary sensor and subtract a difference between the temperature of the sensor and the temperature of the auxiliary sensor from the temperature of the auxiliary sensor to calibrate the auxiliary sensor.

14. The system of claim 1 wherein the housing is supported on feet extending downwardly from a bottom of the housing that are spaced to engage wire racks of the internal cavity therebetween the feet.

15. The system of claim 1 wherein the auxiliary temperature device does not have a heater.

16. The system of claim 1 wherein the housing is sized to contact less than 75 percent of a lower surface of the IV bag supported by the auxiliary housing.

12

17. The system of claim 1 wherein the sensor is bonded beneath the heat collection plate.

18. The system of claim 1 wherein the heat collection plate is a conductive metal.

19. The system of claim 1 wherein the heat collection plate has a gauge thickness of less than or equal to 0.01 inches.

20. A method of detecting a temperature of an IV bag placed within a warming cabinet comprising a housing having an internal cavity; at least one electric heater fixed to the housing and adapted to heat the internal cavity; and a sensor detecting a temperature of air within the internal cavity and communicating with the at least one electric heater to control a temperature of the internal cavity, wherein the temperature is independent of a temperature of the warming cabinet, comprising the steps of:

placing an auxiliary temperature device comprising an auxiliary housing, a heat collection plate supported by the housing and having an upwardly exposed upper surface configured to support an IV bag thereon opposite a lower surface supporting an insulating layer, the insulating layer positioned between the heat collection plate and the air of the cavity and configured to block heat transfer from the air of the cavity to the lower surface of the heat collection plate, and an auxiliary sensor supported by the heat collection plate and configured to provide a temperature of the IV bag substantially independent of the temperature of the air of the internal cavity within the warming cabinet wherein the auxiliary temperature device is repositionable within the internal cavity independent of a position of all electric heaters within the internal cavity;

connecting the auxiliary temperature device to the warming cabinet;

placing the IV bag on the heat collection plate;

pressing a temperature read out button; and

displaying the temperature of the heat collection plate on a display.

* * * * *